

版本 REV.	变更号 ECN NO.	变更内容 REVISION RECORD	日期 DATE	设计 BY
A	-	初版 FIRST EDITION	2017-03-18	裴亚灵

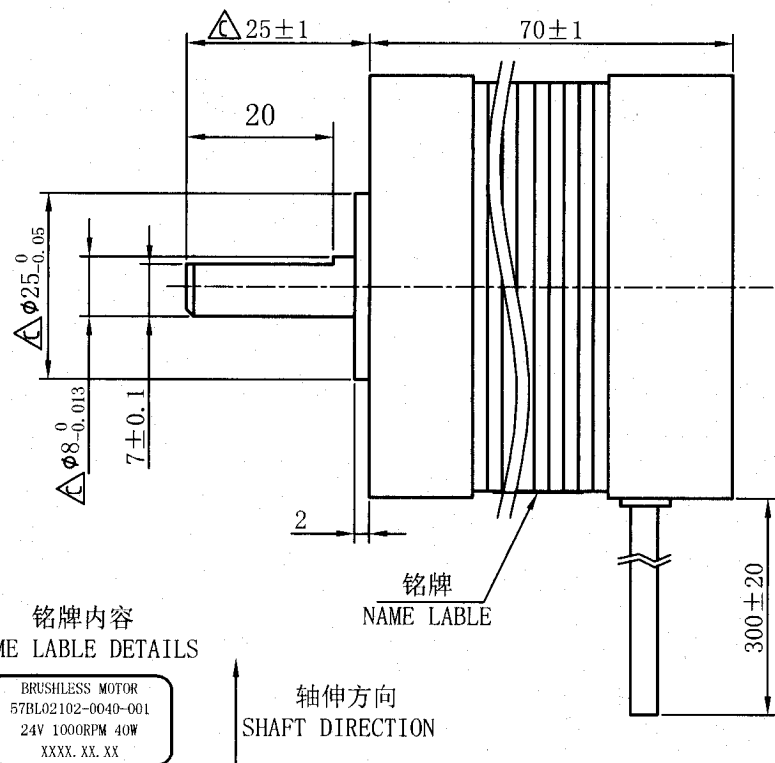

铭牌内容  
NAME LABEL DETAILS

BRUSHLESS MOTOR
57BL02102-0040-001
24V 1000RPM 40W
XXXX.XX.XX

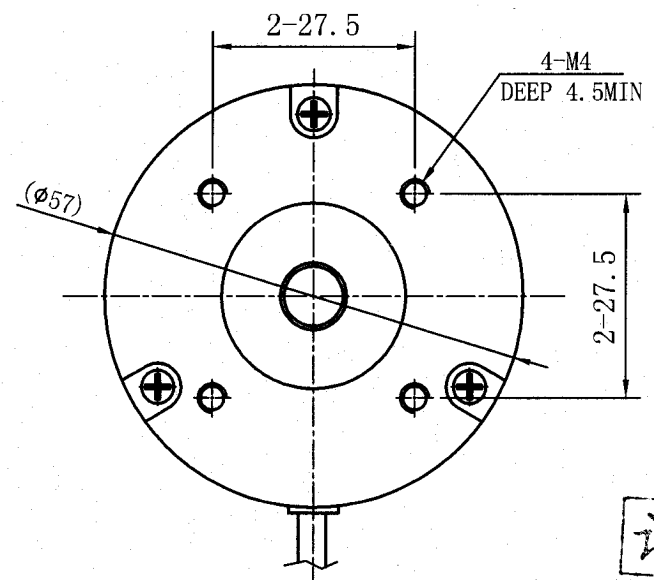

试制

技术规格 TECHNICAL SPECIFICATIONS:

电机型号 MODEL NUMBER	57BL02102-0040-001
相数 PHASE	3
极数 NUMBER OF POLES	8
绝缘等级 INSULATION CLASS	CLASS B
绝缘电阻 INSULATION RESISTANCE	100MΩ MIN., 500VDC
耐压测试 DIELECTRIC STRENGTH TEST	500VDC FOR 1 MINUTE
轴承类型 BEARING TYPE	NMB BALL BEARING, C3
额定电压 RATED VOLTAGE	24VDC
额定转矩 RATED TORQUE	0.382 N.m
额定功率 RATED POWER	40 W
额定转速 RATED SPEED	1000±10% RPM
额定电流 RATED CURRENT	2.5±10% A
空载转速 NO LOAD SPEED	1700 RPM REF
空载电流 NO LOAD CURRENT	0.15 A REF

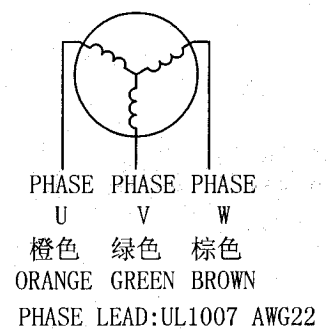
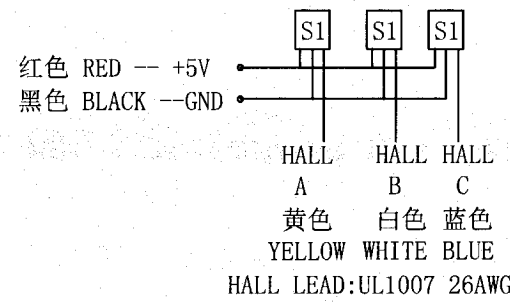

CTQ Sign: $\triangle$ Customer; $\triangle$ Process; $\triangle$ Law		常州运控电子股份有限公司 CHANGZHOU YUNKONG ELECTRONIC CO., LTD	
物料符合RoHS指令要求 all Material are to be RoHS Compliant			
UNLESS OTHERWISE SPECIFIED		SIGNATURE	DATE
Unit:mm	2. 常规公差Tolerances:	裴亚灵	2017-03-18
1. GB/T 1804-m eqv.	角度 Angles: ±0.1°		
ISO 2768-1 class m	标准化 STANDARD		
<=6 ±0.1	第一角画法 FIRST ANGLE METHOD		
>6~30 ±0.2	工艺 TECHNOLOGY		
>30~120 ±0.3	审核 CHECK	2017.3.18	
>120~400 ±0.5	变更标识 ECN SIGN	裴亚灵	2017.3.18
	批准 APPROVE		
		品名 TITLE	57BLDC MOTOR
		图号 DWG. NO.	57BL02102-0040-001
		材料 MATERIAL	---
		版本 REV.	A
		比例 SCALE	1:1
		页 SHEET	1 of 1